

Lifecycle visualization base

Visualizing documents, 2D drawings and 3D models in an easy-to-use collaboration-enabled environment

Benefits

- Extends the value of your existing CAD investments by enabling knowledge users to visualize and leverage product data in standard 2D and 3D format even when this data was created using different authoring software
- Optimizes lifecycle efficiency and reduces IT burden by enabling your entire enterprise to share data without incurring cost, time and resource overhead associated with CAD systems and heavyweight CAD files
- Facilitates richer communication and exchange of intellectual assets throughout globally dispersed enterprises otherwise inhibited by geographic, organizational or technological boundaries
- Allows extended members of your enterprise, such as sales and marketing organizations, allied partners, suppliers and customers, to participate in your development process early and often without the cost, complexity or training typically associated with CAD systems

Summary

Teamcenter® software's lifecycle visualization suite enables enterprises to enhance their product lifecycle management (PLM) environment with a comprehensive family of visualization solutions. Product teams can use lifecycle visualization to communicate and express design intent more effectively, visualize product data in its entirety and perform lifecycle tasks within the context of an overall product definition. Teamcenter's lifecycle visualization base solution provides powerful 2D/3D visualization capabilities that enterprises can quickly deploy within their PLM environment to generate immediate return on investment.

Leveraging intellectual assets throughout the product lifecycle

Teamcenter's lifecycle visualization base capabilities comprise an intuitive and easy-to-use solution that enables enterprise users to access documents, 2D drawings and 3D models in a single environment. Designed for non-technical users and managers who do not have the time to learn complex software (such as a CAD system), base capabilities be mastered users within hours – enabling users to product that were communicated the past.

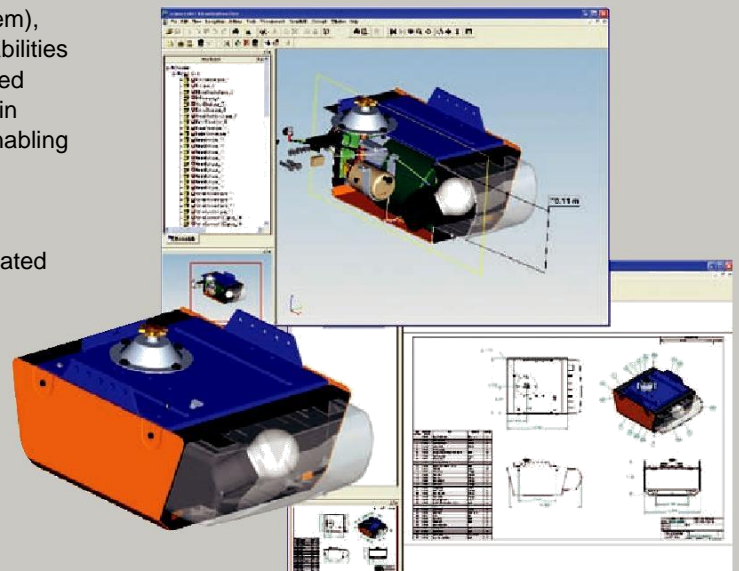

TEAMCENTER

www.siemens.com/teamcenter

SIEMENS

Lifecycle visualization base

Features

The following capabilities are included with any base license of Teamcenter:

- Ability to visualize virtually all 2D formats including PDF, BMP, GIF, JPG, TIFF, CGM, HPGL, IGES, DXF, DWF (6.0 and above) and DWG
- 2D navigation tools, including pan, zoom, rotate, flip, zoom drawing scale, zoom area, seek, fit all and multi-page navigation
- 2D markup tools, including markers, lines, shapes, text, insert image, rubber stamp and GD&T markup
- 2D measurement tools, including linear, radial and angular measurement
- 2D compare
- Basic 3D measurement (single point and point-to-point)
- Basic 3D sectioning (X, Y, Z axes only)
- Ability to view and interact with product manufacturing information (PMI)
- Ability to export images to various formats, including JPG, PNG, BMP, TIFF and HPGL
- Ability to visualize multi-CAD assemblies in JT format from major CAD systems, including NX™ software, Catia, Pro/Engineer, Solid Edge® software, AutoCAD, Autodesk, Inventor, CADDs and SolidWorks
- Ability to visualize product structure
- 3D navigation tools, including rotate, pan, zoom, fit all, zoom area and seek

Teamcenter lets enterprises unlock product knowledge created across multiple disciplines and leverage these highly valuable intellectual assets throughout the entire product lifecycle. By providing users with access to an enterprise's entire wealth of intellectual assets, Teamcenter enables users in one discipline to leverage knowledge created by other disciplines and apply these untapped assets when developing innovative new products and improving lifecycle processes.

Visualization leadership

Teamcenter has proven its credentials by providing the world's leading set of visualization solutions for more than a decade and delivering unmatched performance and a solution portfolio of unsurpassed breadth. Teamcenter not only provides your enterprise with the best visualization technology on the market today, but also enables you to collaborate with industry-leading companies around the world.

JT Open program

Teamcenter's lifecycle visualization suite is built on the de facto standard JT™ visualization technology. JT is the common 3D language for collaboration, visualization and interoperability between PLM software applications and is supported through an industry initiative known as the JT Open Program. The JT Open Program is an organization driven by global leaders in the PLM industry that have adopted the JT format and advocate its use as a standard. The JT Open Program, as the name implies, is open to commercial manufacturers, independent software vendors, academic institutions and even Siemens' competitors who endeavor to champion the JT technology foundation, proliferate its usage and sustain its position as the industry standard for visualization, collaboration and knowledge exchange.

Capabilities

Teamcenter's lifecycle visualization base solution delivers a wide variety of functional capabilities, including:

- Visualization capabilities that enable users to easily visualize and examine documents, raster images, vector drawings and 3D models
- Advanced performance settings that allow users to visualize even the largest and most complex 3D models that cannot be viewed on conventional CAD systems
- Comprehensive 2D annotation tools that enable users to mark up documents and drawings with comments and other notations that clarify design intent – while storing the markup layers separately in industry-standard CGM format to preserve the integrity of the original data
- GD&T markup tool that manufacturing engineers can use to annotate drawings with symbols that instruct designers in how to add GD&T information to a drawing
- Measurement functionalities that allow users to examine and analyze multiple aspects of 2D drawings
- Comparison tools that users can employ to examine different versions of 2D drawings, identify changes and visually determine the impact of given changes
- Save-session procedures that enable users to capture a work session (for example, at the end of the day) and rapidly resume the session at the user's convenience (for example, at the start of new day)
- Real-time collaboration tools that users can leverage to host interactive online review sessions where design ideas are interactively viewed and shared among globally dispersed peers
- Robust security protections that apply user privileges that determine which PLM users are allowed to save local copies of the product data and which users are entitled to modify this data under their PLM system of choice

Features *continued*

- 2D and 3D navigator window
- Save session
- Peer-to-peer conferencing
- Integration with Teamcenter's engineering process management, manufacturing process management, community collaboration and enterprise knowledge foundation solutions
- Windows and Unix support

Scalable solution that grows with your enterprise

The following Teamcenter lifecycle visualization service levels enable you to scale and extend the scope of your visualization solution to match the physical and functional growth of your enterprise.

Lifecycle visualization base – a powerful visualization solution that provides 2D and 3D visualization functionality, extensive 2D markup tools and 2D investigation tools, including measurement and comparison capabilities. Includes basic 3D viewing plus ability to visualize product structure.

Lifecycle visualization standard – an enterprise 2D/3D view and markup solution that provides advanced 3D visualization functionality, powerful 3D markup tools, 3D measurement and access to advanced product data including product manufacturing information (PMI).

Lifecycle visualization professional – a full-function design review solution with 3D investigation tools, including cross-section, 3D comparison and user-defined coordinate system capabilities that allow users to perform analysis on multi-CAD assemblies – collaboratively – without using a CAD system.

Lifecycle visualization mockup – a sophisticated digital mockup solution used to assemble a complete digital prototype, perform advanced analysis – including static and dynamic clearance analysis on the whole product – and detect issues early. Optional add-ons include analysis, clearance server, illustration, Jack™ software (ergonomics), VSA (tolerance analysis), quality, animation creation and path planning.

iSeries – an easy to deploy and maintain web browser-based implementation of the lifecycle visualization base, standard and professional service levels.

Dodavatel:
TPV group s.r.o.
 Brigádnická 124
 Třemošnice 538 43
 +420 469 661 054
www.tpvgroup.cz



Contact
 Siemens PLM Software
 Americas 800 498 5351
 Europe 44 (0) 1276 702000
 Asia-Pacific 852 2230 3333

www.siemens.com/teamcenter

© 2011 Siemens Product Lifecycle Management Software Inc. All rights reserved. Siemens and the Siemens logo are registered trademarks of Siemens AG. D-Cubed, Femap, Geolus, GO PLM, I-deas, Insight, JT, NX, Parasolid, Solid Edge, Teamcenter, Tecnomatix and Velocity Series are trademarks or registered trademarks of Siemens Product Lifecycle Management Software Inc. or its subsidiaries in the United States and in other countries. Jack is a trademark or registered trademark of The Trustees of The University of Pennsylvania. All other logos, trademarks, registered trademarks or service marks used herein are the property of their respective holders. X3 3237 2/11 C